



## DM74S287 (256 x 4) 1024-Bit TTL PROM

### General Description

This Schottky memory is organized in the popular 256 words by 4 bits configuration. Memory enable inputs are provided to control the output states. When the device is enabled, the outputs represent the contents of the selected word. When disabled, the 4 outputs go to the "OFF" or high impedance state.

PROMs are shipped from the factory with lows in all locations. A high may be programmed into any selected location by following the programming instructions.

### Features

- Advanced titanium-tungsten (Ti-W) fuses
- Schottky-clamped for high speed
  - Address access—down to 30 ns max
  - Enable access—20 ns max
  - Enable recovery—20 ns max
- PNP inputs for reduced input loading
- All DC and AC parameters guaranteed over temperature
- Low voltage TRI-SAFETM programming
- > 2000V input protection for electrostatic discharge
- TRI-STATE® outputs

### Block Diagram

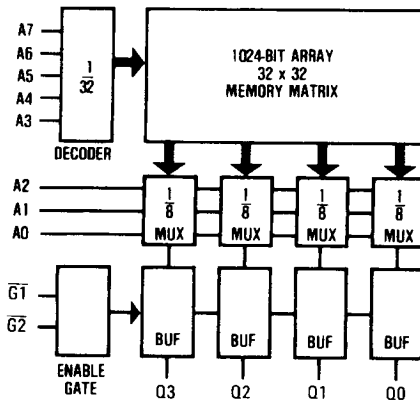

Pin Names

A0-A7	Addresses
$\overline{G1}, \overline{G2}$	Output Enables
GND	Ground
Q0-Q3	Outputs
VCC	Power Supply

TL/D/8359-1

## Connection Diagrams

### Dual-In-Line-Package

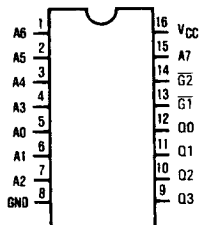

Top View

TL/D/8359-2

Order Number DM74S287J, 287AJ,  
287N or 287AN  
See NS Package Number J16A or N16A

### Plastic Leaded Chip Carrier (PLCC)

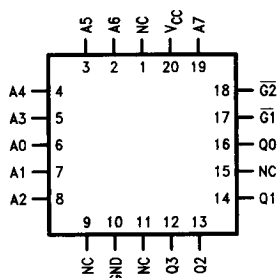

Top View

TL/D/8359-7

Order Number DM74S287V or 287AV  
See NS Package Number V20A

## Ordering Information

Commercial Temp Range (0°C to +70°C)

Parameter/Order Number	Max Access Time (ns)
DM74S287AJ	30
DM74S287J	50
DM74S287AN	30
DM74S287N	50
DM74S287AV	30
DM74S287V	50

**Absolute Maximum Ratings** (Note 1)

If Military/Aerospace specified devices are required, please contact the National Semiconductor Sales Office/Distributors for availability and specifications.

Supply Voltage (Note 2)	-0.5 to +7.0V
Input Voltage (Note 2)	-1.2V to +5.5V
Output Voltage (Note 2)	-0.5V to +5.5V
Storage Temperature	-65°C to +150°C
Lead Temp. (Soldering, 10 seconds)	300°C
ESD	>2000V

**Operating Conditions**

	Min	Max	Units
Supply Voltage ( $V_{CC}$ )			
Commercial	4.75	5.25	V
Ambient Temperature ( $T_A$ )			
Commercial	0	70	°C
Logical "0" Input Voltage	0	0.8	V
Logical "1" Input Voltage	2.0	5.5	V

**DC Electrical Characteristics** (Note 3)

Symbol	Parameter	Conditions	DM74S287			Units
			Min	Typ	Max	
$I_{IL}$	Input Load Current	$V_{CC} = \text{Max}, V_{IN} = 0.45V$		-80	-250	$\mu A$
$I_{IH}$	Input Leakage Current	$V_{CC} = \text{Max}, V_{IN} = 2.7V$			25	$\mu A$
		$V_{CC} = \text{Max}, V_{IN} = 5.5V$			1.0	mA
$V_{OL}$	Low Level Output Voltage	$V_{CC} = \text{Min}, I_{OL} = 16 \text{ mA}$		0.35	0.45	V
$V_{IL}$ (Note 4)	Low Level Input Voltage				0.80	V
$V_{IH}$ (Note 4)	High Level Input Voltage		2.0			V
$V_C$	Input Clamp Voltage	$V_{CC} = \text{Min}, I_{IN} = -18 \text{ mA}$		-0.8	-1.2	V
$C_i$	Input Capacitance	$V_{CC} = 5.0V, V_{IN} = 2.0V$ $T_A = 25^\circ C, 1 \text{ MHz}$		4.0		pF
$C_o$	Output Capacitance	$V_{CC} = 5.0V, V_O = 2.0V$ $T_A = 25^\circ C, 1 \text{ MHz}, \text{Outputs Off}$		6.0		pF
$I_{CC}$	Power Supply Current	$V_{CC} = \text{Max}, \text{Inputs Grounded}$ All Outputs Open		80	130	mA
$I_{OS}$	Short Circuit Output Current	$V_O = 0V, V_{CC} = \text{Max}$ (Note 5)	-20		-70	mA
$I_{OZ}$	Output Leakage (TRI-STATE)	$V_{CC} = \text{Max}, V_O = 0.45V \text{ to } 2.4V$ Chip Disabled			+50	$\mu A$
					-50	$\mu A$
$V_{OH}$	Output Voltage High	$I_{OH} = -2.0 \text{ mA}$				V
		$I_{OH} = -6.5 \text{ mA}$	2.4	3.2		V

**Note 1:** Absolute maximum ratings are those values beyond which the device may be permanently damaged. They do not mean that the device may be operated at these values.

**Note 2:** These limits do not apply during programming. For the programming ratings, refer to the programming instructions.

**Note 3:** These limits apply over the entire operating range unless stated otherwise. All typical values are for  $V_{CC} = 5.0V$  and  $T_A = +25^\circ C$ .

**Note 4:** These are absolute voltages with respect to pin 8 on the device and include all overshoots due to system and/or tester noise. Do not attempt to test these values without suitable equipment.

**Note 5:** During  $I_{OS}$  measurement, only one output at a time should be grounded. Permanent damage may otherwise result.

**AC Electrical Characteristics** with Standard Load and Operating Conditions

COMMERCIAL TEMP RANGE (0°C to +70°C)

Symbol	JEDEC Symbol	Parameter	DM74S287			DM74S287A			Units
			Min	Typ	Max	Min	Typ	Max	
TAA	TAVQV	Address Access Time		35	50		20	30	ns
TEA	TEVQV	Enable Access Time		15	25		15	20	ns
TER	TEXQX	Enable Recovery Time		15	25		15	20	ns
TZX	TEVQX	Output Enable Time		15	25		15	20	ns
TXZ	TEXQZ	Output Disable Time		15	25		15	20	ns

**Functional Description****TESTABILITY**

The Schottky PROM die includes extra rows and columns of fusible links for testing the programmability of each chip. These test fuses are placed at the worst-case chip locations to provide the highest possible confidence in the programming tests in the final product. A ROM pattern is also permanently fixed in the additional circuitry and coded to provide a parity check of input address levels. These and other test circuits are used to test for correct operation of the row and column-select circuits and functionality of input and enable gates. All test circuits are available at both wafer and assembled device levels to allow 100% functional and parametric testing at every stage of the test flow.

**RELIABILITY**

As with all National products, the Ti-W PROMs are subjected to an on-going reliability evaluation by the Reliability Assurance Department. These evaluations employ accelerated life tests, including dynamic high-temperature operating life, temperature-humidity life, temperature cycling, and thermal shock. To date, nearly 7.4 million Schottky Ti-W PROM device hours have been logged, with samples in Epoxy B molded DIP (N-package), PLCC (V-package) and CERDIP (J-package). Device performance in all package configurations is excellent.

**TITANIUM-TUNGSTEN FUSES**

National's Programmable Read-Only Memories (PROMs) feature titanium-tungsten (Ti-W) fuse links designed to program efficiently with only 10.5V applied. The high performance and reliability of these PROMs are the result of fabrication by a Schottky bipolar process, of which the titanium-tungsten metallization is an integral part, and the use of an on-chip programming circuit.

A major advantage of the titanium-tungsten fuse technology is the low programming voltage of the fuse links. At 10.5V, this virtually eliminates the need for guard-ring devices and wide spacings required for other fuse technologies. Care is taken, however, to minimize voltage drops across the die and to reduce parasitics. The device is designed to ensure that worst-case fuse operating current is low enough for reliable long-term operation. The Darlington programming circuit is liberally designed to insure adequate power density for blowing the fuse links. The complete circuit design is optimized to provide high performance over the entire operating ranges of  $V_{CC}$  and temperature.